

Ventilation Equipment
Odour reduction hood for 6 on 6 GN 1/1
or 6 on 10 GN 1/1 stacked electric
lengthwise combi ovens

ITEM # _____

MODEL # _____

NAME # _____

SIS # _____

AIA # _____

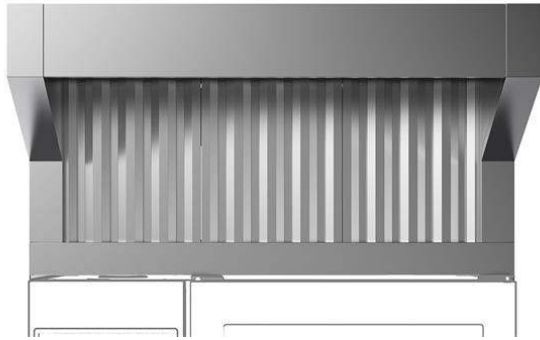
922722 (HOOS11E)

 Odourless hood with fan for
 6+6 or 6+10 GN 1/1 electric
 ovens

Main Features

- Filtering surface protects against fire hazard.
- No need for an external exhaust pipe, thus eliminating carpentry costs.
- Complete ventilation system which eliminates the need for an exhaust duct with external connection.
- UV system attacks the fat molecules eliminating unpleasant odours and bacteria; post-filters restrain the residual odours and no reacted ozone.
- Fan motor with 3 automatic speeds:
 - Low speed when door is closed and valve is closed;
 - Medium speed when door is closed and valve is open;
 - High speed when door is open.
- Frontal labyrinth and condensation filters are easy to remove and cleanable in a dishwasher.
- Possibility to activate air purification system when the oven is in stand by (not cooking) or in cleaning phase.
- The cable connection between the hood and the oven makes possible the communication between them. Connection of the hood to the oven's software automatically activates fan power and odour absorption based on real oven activity.
- The hood and the oven are synchronized: the hood switches On/Off when the oven starts/stops; based on real oven activity the hood automatically activates Hi/Medium/Low fan power for odour absorption.
- Can be used with 6 on 6 GN 1/1 or 6 on 10 GN 1/1 stacked electric LW combi ovens.
- Double step door opening (PNC 922265) is suggested to improve filtering performance.
- Calculate the air exchange rate for the complete kitchen environment and ensure the compliance with ventilation norms (e.g. VDI 2052 Standard for ventilation of commercial kitchens - or any local reference). An insufficient air exchange rate may cause mal

Construction

- Constructed entirely in 304 AISI stainless steel.
- Automatic door opening activation system.
- Multiple filtration systems:
 - prefiltering of exhaust steam through stainless steel labyrinth filters;
 - condensation filter and extra droplets separator acting as a steam-liquid separator;
 - UV system attac
- Developed and produced in ISO 9001, ISO 14001 and ISO 50001 certified factory.
- Must be installed in a space where normal

APPROVAL: _____

eration, according to regulations, is present.

Sustainability



- System guarantees correct suction as well as high energy saving.

Front

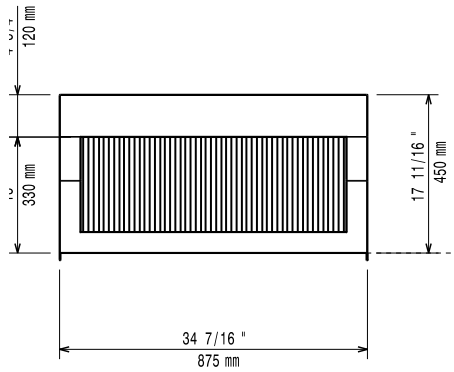

Side

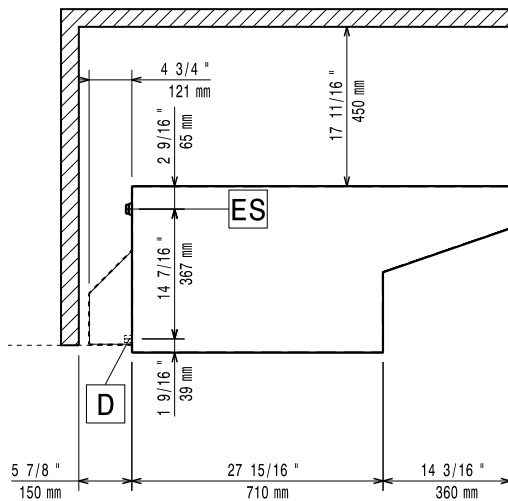

EI = Electrical inlet (power)

Top

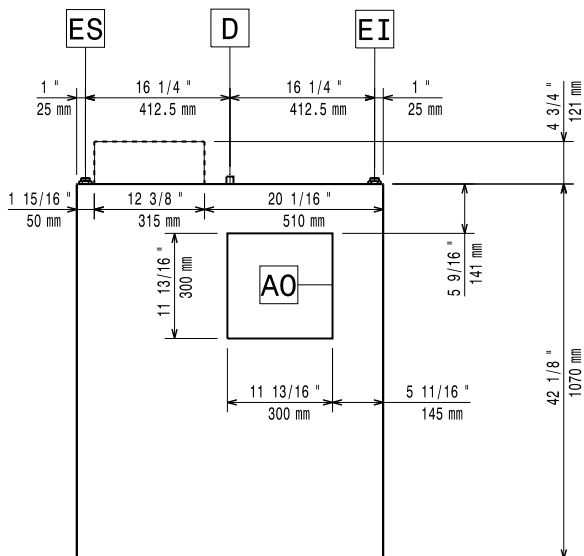
Electric

 Supply voltage: 220/240 V/1 ph/50 Hz
 Default Installed Power: 0.82 kW

Key Information:

 External dimensions, Width: 875 mm
 External dimensions, Depth: 1070 mm
 External dimensions, Height: 472 mm
 Net weight: 97 kg

Air Emission:

 Air capacity: 1200-1500 m³/h